

DAMMER DIKER™ OWNER/OPERATOR MANUAL

Ag Engineering and Development Company, Inc., welcomes you to the growing family of Dammer Diker users. Although Reservoir Tillage will be the primary use of your new Dammer Diker, it is suited for many other farming tasks. The Sales and Engineering personnel at Ag Engineering can help you to determine the suitability of your equipment for those tasks. Your new Dammer Diker has been built to give years of rugged service and was assembled and configured to meet the requirements of your specific crops, cropping patterns, and farming practices. Your machine is adjustable and may be suited to other configurations.

Carefully read the information contained in this manual regarding the safe operation and maintenance of the equipment. Proper adjustment and regular service will insure long and profitable operation of your new equipment. Replacement parts and service are readily available from your local dealer or salesman and/or by calling the factory direct at 1-800-627-9099. The following information should be recorded so it is readily available for ordering replacement parts or to aid in determining suitability for alternate uses.

Specifications for your machine can be recorded below:

SERIAL NUMBER _____

TOOLBAR MODEL NUMBER _____

SHANK TYPE AND SIZE _____

SPIDER SIZE, SPOKE & BLADE _____

DEALER OR SALES REPRESENTATIVE _____

AG ENGINEERING AND DEVELOPMENT CO., INC.
PO BOX 2814
TRI-CITIES, WASHINGTON 99302
509-582-8900

PATENTS

Your Dammer Diker™ is manufactured under US, Patent #4,508,177 and Canadian Patent #1,227,683. Other patents are pending. It is unlawful to manufacture, sell, or use items protected by patent law without appropriate license. Ag Engineering and Development Company, Inc., is the exclusive licensee of the Dammer Diker™ and as such are required to vigorously protect the rights guaranteed under patent law.

LIMITED WARRANTY

Ag Engineering and Development Co., Inc., warrants our products to be free from defects in workmanship and materials if used in accordance with normal field applications. The obligation under this warranty is to replace or repair any part that we have determined to be defective. The Ag Engineering cannot be responsible for any failure if the machine has been altered or used in any manner contrary to normal usage. If there is a claim for warranty it must be in writing. Any defective parts may be requested and inspected by Ag Engineering. This warranty will be valid for one (1) year from the date of delivery. Ag Engineering cannot be liable for any injury or accident involving the equipment or any other damages of any kind or description through the use of said machine.

For information regarding this warranty and your rights under this warranty, contact Ag Engineering and Development Co., Inc., PO Box 2814, Tri-Cities Washington, 99302.

SPECIFICATIONS

TRACTOR REQUIREMENTS

The tractor will need to be equipped with a Category II, III, or IV wide or narrow three-point hitch to attach to the Dammer Diker™. Dammer Dikers™ may be manufactured as Category II-III, Category III, Category III-IV, or Category IV. Be sure that the tractor and the implement hitches are compatible. Draft or load sensing are useful options. Quick hitches with the same specifications are useful and recommended. The pull-type Dammer Diker™ does not require three-point hitches.

Note: If a quick hitch is not used, the tractor center link should be attached to the bottom Category III center mast hole. When using any of the other holes in the center mast, install a spacer in the bottom hole to prevent premature mast failure.

Tractor horsepower requirements will vary with soil conditions and will typically range from 15 to 25 horsepower per shank being pulled. For example: a 7-shank diker (6 row) would require a tractor from 100 to 175 horsepower depending on soil conditions, etc.

SHANK REQUIREMENTS

A variety of ripper shanks are available to be used in the Dammer Diking operation. They should be capable of being pulled at depths up to 12 inches and should be configured to correspond to soil type and crop type. Questions of compatibility should be directed to your Dealer, Sales Representative, or to Ag Engineering personnel.

AE HEAVY DUTY COIL SHANK: This is a coil spring shank that is suitable for use in light, moderately rocky soil conditions. Currently, this shank is not available.

AE ANGULAR SHANK: This is a heavy duty shank that is suitable for use in light to heavy soils with few rocks or obstructions. It is available in 1 inch and 1 1/4 inch models.

AE PARABOLIC SHANK: This a heavy duty shank that is suitable for use in light to medium soils with few rocks or obstructions and where surface clods are not objectionable. It is available in 1 1/4 inch size only.

AE HYDRAULIC RESET ANGULAR SHANK: This is a heavy duty shank made from T1 steel that is suitable for use in most conditions. It is available in 1 inch and 1 1/4 inch models.

AE HYDRAULIC RESET EXTENDED SHANK: This is a heavy duty 1 1/4 inch T1 steel shank that is suitable for ripping beyond the 12 inch normal depth. This shank is suitable for fumigation and other special applications.

TOOLBAR STABILIZATION

The toolbar must be operated in a level position. This is generally accomplished by adjusting the center link of the tractor three-point hitch. Toolbar operating height should be controlled by using gauge wheel assemblies mounted to the toolbar preferably not in the guess row. On smaller, lighter dikers or where tractor tires interfere, toolbar height may be regulated by the tractor's draft control.

TOOLBAR CLASSIFICATIONS

Toolbars are manufactured in a variety of sizes, shapes and configurations to accommodate specific shanks, specific row spacing, specific hitch categories, and specific number of shanks. The following classifications are guidelines in helping to decide what toolbar to use.

STANDARD DUTY TOOLBAR: Available for two and four row diking in average field and soil conditions using coil, angular or parabolic shanks. The hitch is normally Category II-III.

MEDIUM DUTY TOOLBAR: Available for six and eight row diking in average field and soil conditions using angular or parabolic shanks. The hitch is normally Category II-III.

HEAVY DUTY TOOLBAR: Available for two, six, eight, and twelve row diking in adverse field and soil conditions such as rocks, heavy clay, hard pans, or where tractors with excess horsepower are being used with coil, angular, parabolic, or hydraulic reset shanks. The hitch is normally category III, but categories III-IV or IV are available.

HIGH PLAINS TOOLBAR: Available for four, six, and eight row diking in average field and soil conditions using the straight high plains ripper shank. The hitch is normally category II-III.

TILLAGE MASTER TOOLBAR: Available for two, four, six, eight, and twelve row dikers and tillage masters using high plains, shear-trip or hydraulic reset shanks for almost all field and crop conditions. The hitch is normally category III, but categories III-IV or IV are available.

CUSTOM TOOLBARS: Available in a variety of sizes, types, and configurations. They are designed by Ag Engineering to meet the customers' specifications and operation requirements.

DIKER OPERATION AND ADJUSTMENT

The Dammer Diker™ is well suited for use with most row crops under sprinkler irrigation. The ripper shanks are set at the crop row spacing so as to be centered between each row. Ripper depth is set using gauge wheels or the tractor depth control. The diking spiders are set directly behind the ripper shanks and are adjusted to run at the same depth as the shank. The number of spokes and the size of the blades on the spider determine size of the tillage reservoir. Your Dammer Diker™ can be adjusted to operate very well at speeds in the 4 to 6 MPH range. Crop size (stage of growth) and row spacing along with soil conditions dictate how fast you can operate your machine. If you have questions regarding operational speeds or other adjustments, please contact your Dealer, Sales Representative, or Ag Engineering personnel.

SAFETY PRECAUTIONS

The safe operation of your Dammer Diker™ is a top priority with Ag Engineering. Please review with all operators and mechanics the following list of precautions to help insure the safe operation of your machine.

- 1. DO NOT RIDE OR WORK ON MACHINE WHILE IT IS OPERATING OR IN MOTION.**
- 2. SECURELY BLOCK THE MACHINE WHILE WORKING ON IT, OR WHEN SERVICING OR ADJUSTING THE IMPLEMENT.**
- 3. USE CAUTION WHILE WORKING NEAR THE SHARP EDGES OF THE BLADES.**
- 4. CHECK MACHINE PERIODICALLY TO INSURE ALL BOLTS AND FASTENERS ARE SECURE AND PROPERLY TIGHTENED. REPLACE ANY DAMAGED AND WORN PARTS.**
- 5. WHEN TRANSPORTING THE MACHINE, DO SO ONLY ATTACHED TO A TRACTOR OF SUFFICIENT SIZE TO PROPERLY OPERATE YOUR DAMMER DIKER IN THE FIELD. MAINTAIN SUFFICIENT FRONT-END WEIGHT TO ADEQUATELY COUNTERBALANCE THE WEIGHT OF THE DAMMER DIKER FOR PROPER STEERING CONTROL.**
- 6. CONSULT AND FOLLOW YOUR TRACTOR MANUFACTURER'S SAFETY RECOMMENDATIONS AND OPERATING PROCEDURES.**
- 7. USE CAUTION AND FOLLOW ALL LOCAL LAWS WHILE TRANSPORTING YOUR OVER-WIDTH IMPLEMENT ON PUBLIC HIGHWAYS.**
- 8. YOUR NEW IMPLEMENT WAS SHIPPED WITH SAFETY DECALS ATTACHED. SHOULD THEY BECOME OBSCURED OR DAMAGED, PLEASE REQUEST REPLACEMENTS FROM AG ENGINEERING & DEVELOPMENT CO., INC. SEE SAFETY DECAL SECTION FOR MORE INFORMATION.**
- 9. THE HYDRAULIC SYSTEMS ON YOUR MACHINE ARE UNDER PRESSURE AT ALL TIMES. DO NOT ATTEMPT TO ADJUST OR SERVICE THE HYDRAULIC SYSTEMS WITHOUT READING THE INSTRUCTIONS FOR THE "ASSEMBLY OF THE HYDRAULIC RESET SHANK" OR "SERVICING THE ACCUMULATOR."**

SAFETY DECALS

The following decals are attached as appropriate to your new machine and are available at no cost for replacement of damaged or obscured decals.

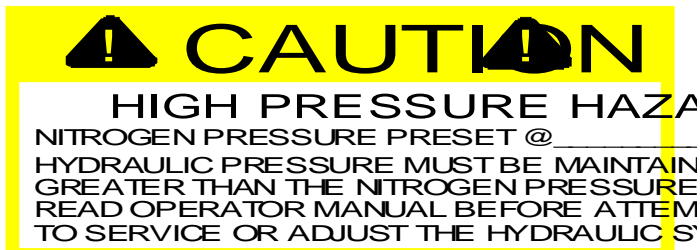
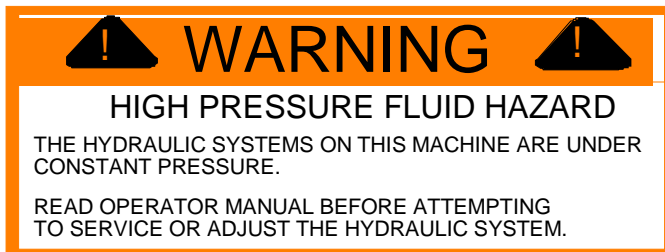

CALL US AT 800-627-9099 TO ORDER DECALS.

ASSEMBLY INSTRUCTIONS

Most new Dammer Dikers™ are shipped mostly assembled from the factory. Sometimes they are shipped unassembled, so we include in this manual procedures for the assembly of your Dammer Diker™.

TOOLBARS

Some toolbars come welded together and require no further assembly. These toolbars can be set on saw horses or blocks at a height that will allow you to add the ripper shanks without them hitting the floor or the ground.

Note: Tillage Master style toolbars must be blocked or clamped to prevent the toolbar from rolling backwards or flipping as all the shank weight is placed on the rear of the toolbar.

Follow the subsequent steps for toolbars that must be bolted together:

1. Set the front (4x6 with center mast and pull ears) toolbar on saw horses or blocks at a height that will allow the shanks to be added at a later time without hitting the floor or ground.
2. Mark on the front toolbar the location of the ripper shank at your selected row spacing (30, 34, 36, etc.) Always measure from the center of the toolbar to the outside in both directions.
3. Determine the number of toolbar spacers and angle spacers shipped with your toolbar. Beginning at the center of the toolbar, lay out the spacers symmetrically in both directions. They should generally be located at midpoints between shanks but may be adjusted either direction to accommodate other equipment such as arm assemblies, gauge wheel assemblies, or hilling wings.
4. Set the rear (4x4 or 4x6) toolbar on the saw horses or blocks at a distance approximately equal to the length of the spacers behind the front toolbar.
5. Install all spacers with appropriate bolts and nut plates. They should first be installed loosely until all spacers are in position and the toolbars are level and square.
6. Tighten all bolts beginning on the outside of the toolbar starting first on front and then rear, right and then left side, observing that toolbars remain level and straight.

CLAMP OR MAST ASSEMBLIES

1. Clamp assemblies or masts for the type of shank you have selected should be loosely bolted to the toolbar at the shank locations you have previously marked.

2. The exploded assembly diagrams at the back of this manual should aid in determining proper bolt sizes and locations.
3. Do not tighten clamps into position until shanks have been attached and tightened to the clamp.
4. Tillage Master style masts may be tightened to the toolbar prior to attaching the shanks. Tighten the middle mast first, then, work towards the outside in both directions.

SHANK ASSEMBLIES

1. Attach shanks to the clamp or mast assemblies. Check the exploded assembly diagrams in the back of this manual to help determine proper bolt sizes and locations.
2. Tighten all bolts that securely fasten the shanks to their respective clamps or masts.
3. You may now tighten the clamp assemblies to the toolbar. Begin with the center shank clamp assembly. Observe that the shank and clamp are located perpendicular to the toolbar and that everything appears proper.
4. The remaining clamp assemblies are secured working from the inside out. Make all measurements from the center shank so that if you do make an error in measuring, it will not be accumulative.
5. Add wear points and any accessories such as hilling wings at this point

STANDARD HYDRAULIC RESET SHANK ASSEMBLIES: A-2508, A-2509

Hydraulic reset shanks are held in the working position by hydraulically charged cylinders that are maintained at a constant pressure by a precharged, nitrogen filled accumulator. Hydraulic oil is considered to be noncompressible. Nitrogen gas is highly compressible. When the hydraulic reset shank encounters an obstruction, the shank trips by compressing the nitrogen gas with a small increase in hydraulic pressure. The hydraulic oil displaces nitrogen gas until the obstruction is cleared then the shank is reset and the system returns to a constant pressure. The following steps should be followed to set up these shank assemblies:

Each shank should be assembled in place on the toolbar. Start by sliding the mast for the center shank into its proper location and insert the two bolts that will clamp the mast to the toolbar. Continue until all masts have been located on the toolbar with the clamp bolts, nuts, and lock washers in place-finger tighten only.

2. Install the hydraulic cylinders in the masts that have been mounted on the toolbar. Insert the bushing in the top of the cylinder and install the cylinder in the mast using the correct bolt.

Note: Appropriate bolt and bushing sizes may be determined by examining the exploded assembly diagram for the shank and mast being installed.

3. Remove the plugs from the cylinder ports and install the 1/2 inch tee in the sleeve end port and the air breather in the rod end port. Teflon tape or sealing compound should be used to insure a leak proof installation. Cylinders have been tested and may have some residual oil inside. Use caution to avoid squirting oil in eyes etc.

4. Mount the accumulator bracket and manifold to the toolbar bridge in a location easily visible to the tractor operator. The manifold should be mounted on the backside of the bridge, away from the tractor hitch, and may be located on either side of the center mast, generally between adjacent shanks. Install the accumulator in the bracket so that the 90 degree elbow fitting in the bottom of the accumulator is pointing to the rear of the machine.

5. Install the valve, gauge, and fittings as indicated in the accumulator exploded assembly diagram.

6. Install the accumulator hose from the indicated port in the manifold to the bottom of the accumulator. Install hoses in the two side ports of the manifold and run them to each adjacent cylinder. Install hoses between each adjacent cylinder working outward from the manifold. Teflon tape or sealing compound should be used so that all joints are free from leaks.

7. Install the 1/2 by 1/8 inch reducer bushing and the small brass bleeder valve in the outside end of the cylinder tee on each end of the machine.

Caution: Tighten the bleeder valve into the bushing using only the wrench flats on the body of the valve. Do not tighten using the hex nut on the end of the valve which opens and closes the valve. Close the bleeder valve finger tight.

8. Install the shanks in their masts next. Insert the bushing in the shank sleeve and mount the shank in the bottom hole of the mast using the appropriate one inch, grade eight bolt. Because of the weight of the shank, two people can best perform this operation, one to hold the shank and the other to insert the bolt from the right side of the mast to the left. Tighten the nut and lock washer on the bolt to a minimum 750 ft-lbs torque. Observe that the inside edges of the mast are securely against both ends of the bushing.

9. Tighten all nuts and bolts beginning with the center shank. Check each shank for horizontal row spacing before tightening the mast bolts that clamp the mast to the toolbar and work inside to outside on the machine.

10. Manually extend the hydraulic cylinders. Lift the shank or extend the cylinder until the clevis and the shank eye mate, then insert the one inch diameter cylinder pin. Secure the pin in the clevis using the tension pins indicated.

Note: The 1/8 in. diameter pin is inserted into the center of the 7/32 in. diameter pin for added strength and must be done before inserting the larger tension pin into the cylinder pin.

11. Grease the fittings at the top of the cylinder and on both sides of each shank. This should be done the first time prior to charging the hydraulic system to insure that grease is placed completely around each bushing.

12. Do a final inspection of all bolts and hydraulic connections to insure that everything is installed and tightened properly. When everything is satisfactory, proceed to the next step and charge the hydraulic system.

CHARGING THE HYDRAULIC SYSTEM FOR A-2508 AND A-2509 SHANK ASSEMBLIES

1. The hydraulic accumulator is pre-charged with nitrogen gas to 1250 psi. The hydraulic reset shanks are designed to work best at this pressure for most operating conditions. Deviations from this pressure should be approved by the factory to avoid warranty invalidations and unsafe conditions. Do not tamper with or attempt to service the hydraulic accumulator without proper instruction or having read and follow the instructions in the section entitled **SERVICING THE HYDRAULIC ACCUMULATOR**.

CAUTION: The accumulator is under high pressure at all times. Escaping gas or oil can cause serious personal injury. If in doubt, call a trained service technician.

2. Attach a hydraulic hose (equipped with the appropriate quick couplers) from the tractor hydraulic valve to the accumulator manifold. Open the ball valve to allow hydraulic flow into the manifold. Before proceeding, double check all connections to make sure they are secure.

3. The bleeder valves on the end cylinders should be opened slightly to allow air to escape from the system as oil is introduced.

CAUTION: Air and then oil will escape from the bleeder valves as the system is charged. Take precautions to protect the surrounding area, equipment and personnel.

4. Slowly charge the system using the tractor valve. When oil starts to escape through the bleeder valve, stop charging and close the bleeder valve or valves.

CAUTION: Do not over tighten the bleeder valve as the threads may strip or the needle may become damaged. Light tension on the wrench is all that is required.

5. Continue slowly charging the system until the pressure gauge on the manifold reads 1350 psi. Inspect the system for leaks in any of the fittings, hoses, or apparatus. Some oil may be observed coming from the air breathers. This is normally from oil left in the cylinder from testing procedures and will stop and should not be a problem.

6. If leaks are observed, relieve the system pressure slowly back into the tractor. Verify that there is no pressure in the system by observing that the pressure gauge is at 0 psi and then slowly open a bleeder valve to relieve any transient pressures. Repair any leaks or faulty equipment and then begin again from step 4 until no leaks are observed and pressure is at 1350 psi.

7. Open bleeder valves one at a time. Bleed the system until oil flows clear without foaming, spitting, or other signs of air in the system. If during this process, the system pressure falls below 500 psi, stop and slowly recharge to 1350 psi again. This process should be repeated until all air has been purged from the hydraulic system.

NOTE: Air in the hydraulic system may allow shanks to trip prematurely or to ride back and not fully reset themselves.

8. Adjust the pressure in the system to 1350 psi, close the ball valve, and disconnect the charging hose from the tractor. Charging is now complete.

CAUTION: The systems oil pressure should be maintained between 1300 psi and 1400 psi at all times. Some slight variations may occur because of temperature fluctuations or as the shanks are tripped. Operating the system at low pressures may cause accumulator damage. The system may be run at higher pressures as long as the nitrogen pressure is also raised to maintain a 100 psi differential between nitrogen and hydraulic pressure. Consult with the factory to determine maximum hydraulic pressures so as not to void the warranty.

HYDRAULIC TILLAGE MASTER

The Tillage Master is a multi-purpose machine that was developed with a special Tillage Master style toolbar, Tillage Master style shank assemblies, and multi-purpose overhead arm assemblies. Two styles of mast are available to mount either hydraulic reset shanks or shear-trip shanks. The first is a standard TM mast and mounts the shank in a position that is close to the rear of the toolbar. The second is a setback TM mast and mounts the shank in a position that is either 16 or 20 inches behind the standard mast creating an offset between the two positions. The overhead arm assemblies allow that rollers, choppers or spiders may be attached to the machine behind the ripper shanks.

Large nitrogen-charged accumulators (2 1/2 gallons) are used to provide down pressure for all hydraulic reset shanks on the Tillage Master. The accumulators are typically pre-charged with 900 psi of dry nitrogen gas for 3 1/2 inch diameter hydraulic cylinders or 1200 psi when 3 inch diameter hydraulic cylinders are used. For extended hydraulic reset shanks, only 3 1/2 inch diameter cylinders are recommended and the nitrogen pre-charge is 1200 psi. Accumulators are pre-charged at the factory and require special equipment and training to be tested or serviced in the field. Contact your dealer or the factory for help in servicing or adjusting pressures in any accumulator.

NOTE: Hydraulic accumulators are protected with threaded covers placed over the charging valves. These covers should not be removed except by a service representative who has the necessary gauges, equipment and training to fill and adjust the gas pressure inside the accumulator. For safety reasons, permanently mounted pressure gauges are not allowed on the gas side of the accumulator.

A small accumulator (1 gallon) provides down pressure for the arm assemblies and is typically pre-charged to 600 psi at the factory.

Overhead arm assemblies are used to attach rollers, choppers, or the spider gangs to the Tillage Master toolbar. Adjustment is accomplished by using either ratchet type screw jacks, or by using hydraulic cylinders charged against a nitrogen charged accumulator. The hydraulic system is preferred and provides the best range of operation and the most protection for the equipment.

The front row of shanks on the Tillage Master is retractable so that the diking operation may be performed without having to remove the center-of-the-row shanks from the toolbar. To retract the front row of shanks, two hydraulic hoses which are attached to the double selector valve will be plugged into a remote hydraulic control valve on the tractor. The instructions for retracting and resetting the shanks are printed on a sticker attached to the machine and are included here for reference.

TO RETRACT FRONT SHANKS:

1. PUSH SPOOL VALVE INWARD.
2. ACTUATE TRACTOR HYDRAULIC VALVE AND RETRACT SHANKS.
3. OPERATE MACHINE WITH VALVE IN THE IN POSITION.

TO ENGAGE FRONT SHANKS

4. ACTUATE TRACTOR HYDRAULIC VALVE AND ENGAGE SHANKS.
5. PULL SPOOL VALVE OUTWARD.
6. OPERATE MACHINE WITH VALVE IN OUT POSITIONS.

NOTE: Any time the Tillage Master is operating and the front shanks are engaged and in the ground, the spool valve must be in the OUT position to prevent damage to the machine. EXTREME CAUTION must be exercised to protect anyone working around the Tillage Master. Attach the Tillage Master to the tractor before adjusting the hydraulic pressures or attempting in any way to service the hydraulic accumulator system. Failure to attach the machine to a tractor may result in the shanks collapsing and the machine falling and crushing anyone near.

TILLAGE MASTER ASSEMBLY INSTRUCTIONS

TOOLBARS

TM toolbars come welded together and require no further assembly. These toolbars can be set on saw horses or blocks at a height that will allow you to add the ripper shanks without them hitting the floor or the ground.

Note: Tillage Master style toolbars must be blocked or clamped to prevent the toolbar from rolling backwards or flipping as all the shank weight is placed on the rear of the toolbar.

Mark on the toolbar your selected row spacing beginning with the center shank and measuring outward to each end. Remember to mark the center of the row locations also.

MAST ASSEMBLIES

1. Masts for the type of shank you have selected should be loosely bolted to the toolbar at the shank locations you have previously marked.
2. The exploded assembly diagrams at the back of this manual should aid in determining proper bolt sizes and locations.
3. Tillage Master style masts may be tightened to the toolbar prior to attaching the shanks. Tighten the middle mast first, then work towards the outside in both directions.

SHANK ASSEMBLIES

1. Attach shanks to the mast assemblies. Check the exploded assembly diagrams in the back of this manual to help determine proper bolt sizes and locations.
2. Tighten all bolts that securely fasten the shanks to their respective clamps or masts.
3. Add wear points and any accessories such as hilling wings after the cylinders, hoses, accumulator etc. have been installed and the system has been charged.

HYDRAULIC RESET SYSTEM

1. Install the 1/2 inch, 45 degree street elbow in the sleeve end port of the hydraulic shank cylinder.
2. Tighten the solid end of the hydraulic hose into each cylinder. Note that the shorter hoses go on the front row cylinders and the longer hoses on the setback row cylinders. The outside cylinders on each row take hoses that are longer than the regular hoses by the row spacing of the machine because the hose from the outside cylinder and the hose from the next to the outside cylinder connect into the same tee on the connecting hose harness.
3. Install a second hose in the rod end port of the front row cylinders. Note again that the two outside cylinders receive hoses that are longer than the other cylinders by the row spacing distance.
4. Install the air breather in the rod end port of the setback cylinders.
5. Install the cylinders in the appropriate shank mast with the hoses going through the center of the mast pointing to the front of the machine. Insert the bushing into the sleeve end of the cylinder. Lower the mast until the bushing lines up with the two top holes in the mast and then insert the 1 inch bolt through the mast and bushing. Add the lock washer and nut.
6. Manually extend the hydraulic cylinders. Lift the shank or extend the cylinder until the clevis and the shank eye mate, then insert the one inch diameter cylinder pin. Secure the pin in the clevis using the tension pins indicated.

Note: The 1/8 inch diameter pin is inserted into the center of the 7/32 inch diameter pin for added strength and must be done before inserting the larger tension pin into the cylinder pin.

7. Mount the accumulator bracket and manifold to the toolbar bridge in a location easily visible to the tractor operator. The manifold should be mounted on the backside of the bridge, away from the tractor hitch, and may be located on either side of the center mast, generally between adjacent shanks. Install the accumulator in the bracket so that the 90-degree elbow fitting in the bottom of the accumulator is pointing to the rear of the machine.

8. Install the valve, gauge, and fittings as indicated in the accumulator exploded assembly diagram.
9. Install the accumulator hose from the indicated port in the manifold to the bottom of the accumulator.
10. Complete the hose harness. Begin with the setback cylinders and connect the hoses from the sleeve end ports to the tees in the connecting harness. The extra line tee in the harness should be located next to the shank closest to the accumulator. A hose will connect from there into the elbow on one end of the accumulator manifold. (See **typical hydraulic schematic.**) Next connect the hoses coming from the sleeve end ports of the front row of shanks to the tees in the connecting harness. Once again locate the extra line tee in the harness next to the shank closest to the accumulator. The connecting hose will go to the manifold port that has the isolator ball valve #1 installed in it.

Connect the hoses from the rod end ports of the front row of cylinders to the tees in a connecting harness. The extra line tee should be located close to the location of the spool valve #2. Connect the hose from the line tee to the spool valve port as shown in the diagram. Note that you should have connected three circuits and connected them independently to the accumulator manifold or the spool valve. Review the schematic one more time and make sure all hoses are routed properly.

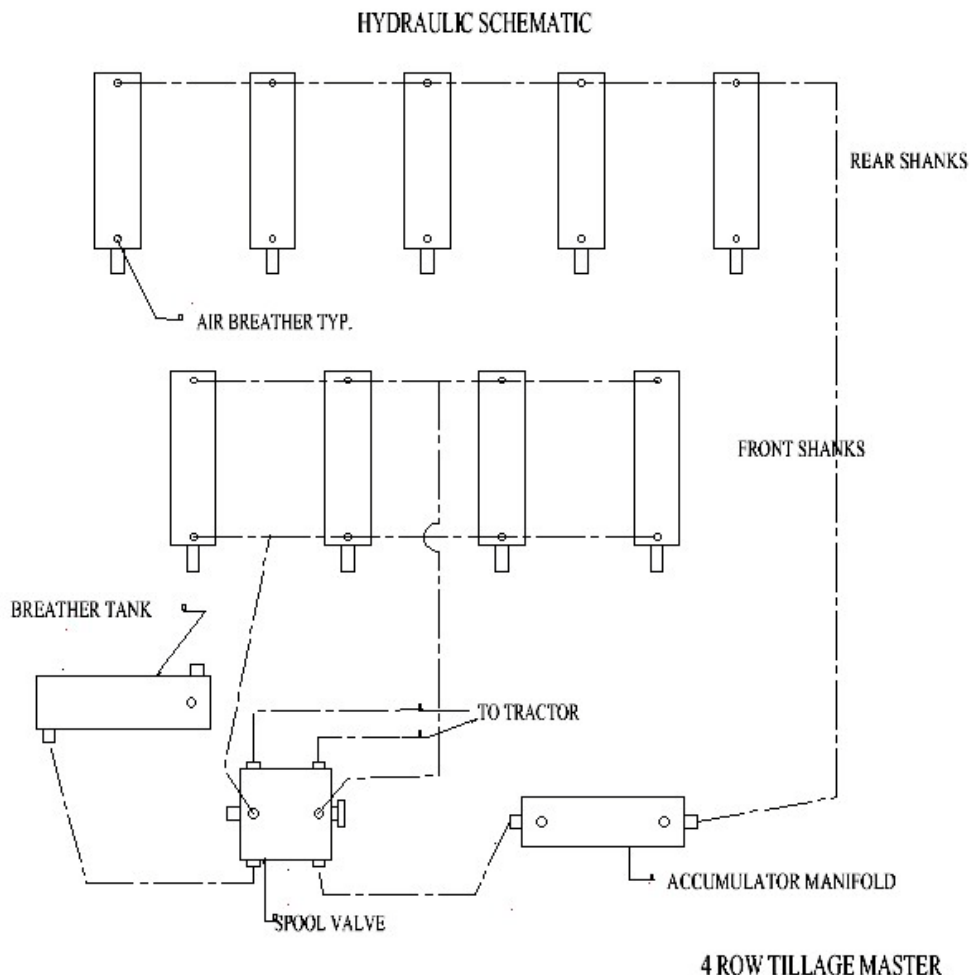

Charging the Hydraulic System

FOR TILLAGE MASTER SHANKS

1. The hydraulic accumulator is pre-charged with nitrogen gas to 900 psi for 3 ½ inch cylinders or 1200 psi for 3 inch cylinders. The hydraulic reset shanks are designed to work best at these pressures for most operating conditions. Deviations from the factory set up pressure should be approved by the factory to avoid warranty invalidations and unsafe conditions. Do not tamper with or attempt to service the hydraulic accumulator without proper instruction or having read and followed the instructions in the section entitled: **SERVICING THE HYDRAULIC ACCUMULATOR.**

CAUTION: The accumulator is under high pressure at all times. Escaping gas or oil can cause serious personal injury. If in doubt, call a trained service technician.

2. Attach a hydraulic hose (equipped with the appropriate quick couplers) from the tractor hydraulic valve to the accumulator manifold. Open the ball valve to allow hydraulic flow into the manifold. Before proceeding, double check all connections to make sure they are secure.

3. The bleeder valves on the end cylinders should be opened slightly to allow air to escape from the system as oil is introduced.

CAUTION: Air and oil will escape from the bleeder valves as the system is charged. Take precautions to protect the surrounding area, equipment, and personnel.

4. Slowly charge the system using the tractor valve. When oil starts to escape through the bleeder valve, stop charging and close the bleeder valve or valves.

CAUTION: Do not over tighten the bleeder valve as the threads may strip or the needle may become damaged. Light tension on the wrench is all that is required.

5. Slowly continue charging the system until the pressure gauge on the manifold reads 1000 psi. Inspect the system for leaks in any of the fittings, hoses, or apparatus. Some oil may be observed coming from the air breathers. This is normally from oil left in the cylinder from testing procedures and will stop and should not be a problem.

6. If leaks are observed, relieve the system pressure slowly back into the tractor. Verify that there is no pressure in the system by observing that the pressure gauge is at 0 psi and then slowly open a bleeder valve to relieve any transient pressures. Repair any leaks or faulty equipment and then begin again from step 4 until no leaks are observed and pressure is at 1000 psi.

7. Open bleeder valves one at a time and bleed the system until oil flows clear without foaming or spitting or other signs of air in the system. If during this process, the system pressure falls below 500 psi, stop and slowly recharge to 1000 psi again.

The process should be repeated until all air has been purged from the hydraulic system.

NOTE: Air in the hydraulic system may allow shanks to trip prematurely or to ride back and not fully reset themselves.

8. Adjust the pressure in the system to 1000 psi for 3 ½ inch cylinders and 1300 psi for 3 inch cylinders, close the ball valve, and disconnect the charging hose from the tractor. Charging is now complete.

CAUTION: The systems oil pressure should be maintained between 50 psi and 100 psi above the preset nitrogen pressure at all times. Some slight variations may occur because of temperature fluctuations or as the shanks are tripped. Operating the system at low pressure may cause accumulator damage. The system may be run at higher pressures as long as the nitrogen pressure is also raised to maintain a 100 psi differential between nitrogen and hydraulic pressures so as not to void the warranty.

SERVICING THE HYDRAULIC ACCUMULATOR

The hydraulic accumulators used on your Dammer Diker™ or Tillage Master are of two different types. The 2 ½ gallon accumulator uses a bladder to separate the nitrogen and oil. The 1 gallon accumulator uses a piston to separate the nitrogen and oil. Both nitrogen charge pressure indefinitely unless the bladder becomes damaged or the charging valve is damaged and leaks. The piston type accumulator is susceptible to seal damage from wear or impurities in the oil.

If you experience difficulty in maintaining hydraulic pressure and there are no visible oil leaks, the accumulators should be checked to verify that the nitrogen pressure is okay.

CAUTION: Always assume that the accumulator is under high pressure. Proper steps must be taken and appropriate equipment used to service or test the accumulator to prevent serious personal injury.

CALL A TRAINED SERVICE TECHNICIAN.

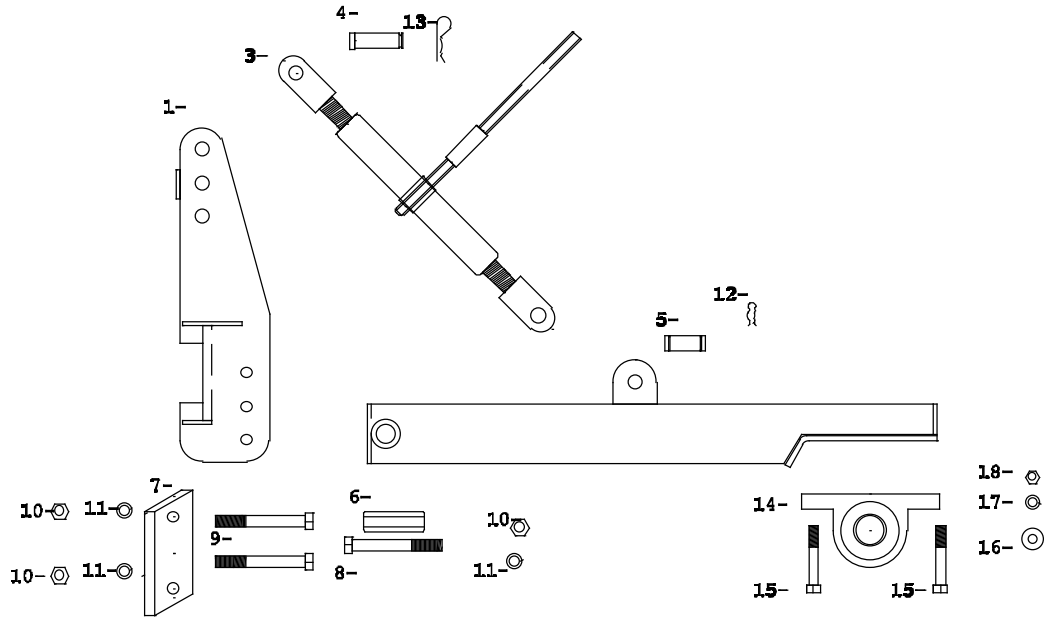

ADJUSTABLE ARM ASSEMBLY: A-2100-1

#	DESCRIPTION	PART NO.	RE	#	DESCRIPTION	PART NO	RE
1	MAST	B-3000	1	10	NUT, 3/4 " Z	75HNCZ	5
2	ARM	B-2100	1	11	LOCK WASHER	75LWZ	5
3	RATCHET JACK	B-3020	1	12	HAIR PIN, 3/32"	B-5110	2
4	PIN, 1" X 2 7/8"	B-5050	1	13	HAIR PIN, 3/16"	B-5070	1
5	PIN 1" X 2"	B-5030	1	14	BEARING, 2 "	B-2104	1
6	BUSHING, 1.365"	B-9702	1	15	BOLT, 5/8 X 4"	62HCS4.0CZ5	2
7	NUT PLATE	B-3050	2	16	FLAT WASHER	62FWZ	2
8	BOLT, 3/4 X 6"	75HCS6.0C Z5	1	17	LOCK WASHER	62LWZ	2
9	BOLT, 3/4 X 6 1/2"	75HCS6.5C Z5	4	18	NUT, 5/8" Z	62HNCZ	2

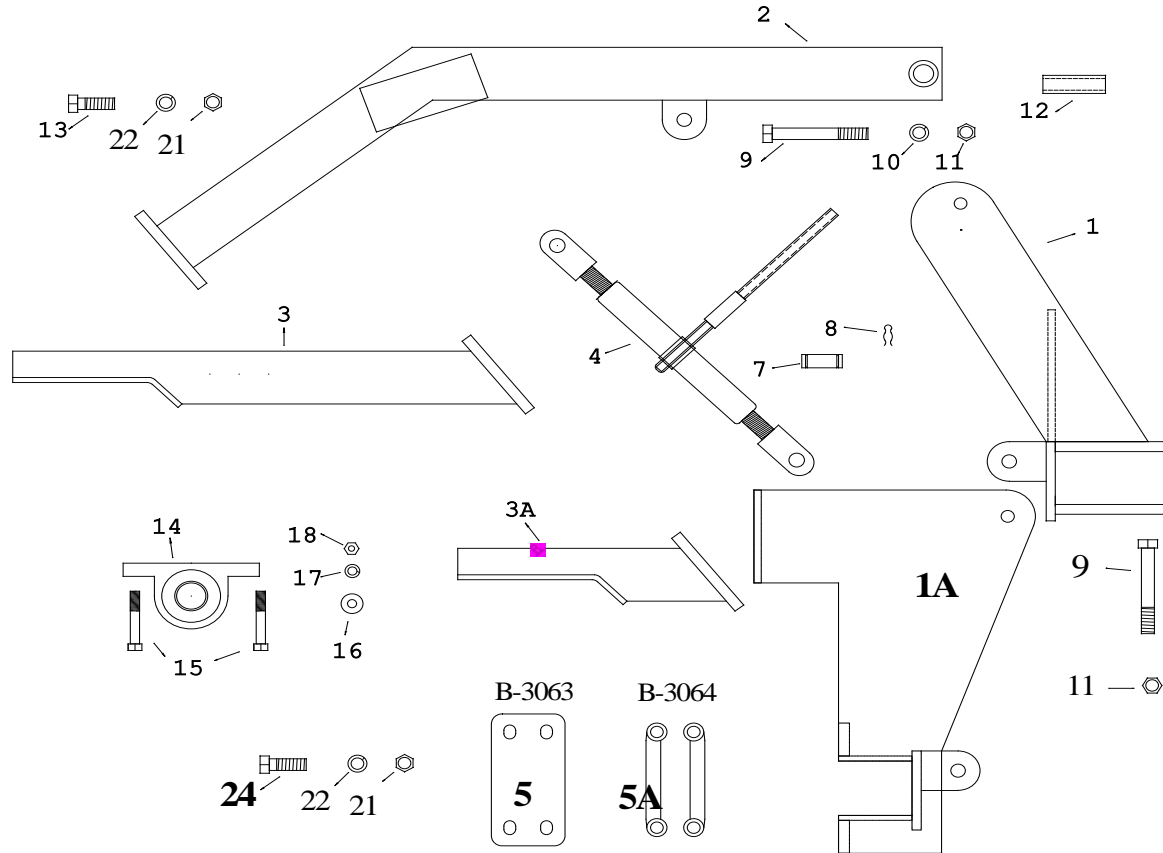

**ADJUSTABLE OVERHEAD ARM ASSY, COMBO:
A-2150-3**

#	DESCRIPTION	PART NO	RE	#	DESCRIPTION	PART NO	RE
1	MAST,OHA	B-3005	0	12	BUSHING, 1.365 X4.25	B-9707	1
1A	MAST, TOP MOUNT	B-3006	1	13	BOLT, 3/4 X 2 1/2"	75HCS2.5CZ5	4
2	ADJ ARM SPACER	B-2150-2	1	14	BEARING, 2"PB	B-2104	1
3	TM SPIDER ARM,	B-2155	1	15	BOLT,5/8 X 4 1/2"	62HCS4.5CZ5	2
3A	TM SPIDER ARM,	B-2156	0	15A	BOLT, 5/8 X 4"	62HCS4.0CZ5	0
3B	TM SPIDER ARM,	B-2157	0	16	FLAT WASHER, 5/8"Z	62FWZ	2
4	RATCHET JACK	B-3020	1	17	LOCK WASHER,	62LWZ	2
5	NUT PLATE, 5 X 10"	B-3063	1	18	NUT, 5/8"Z	62HNCZ	2
5A	NUT PLATES, OPTION	B-3064	0	19	HEX JAM NUT, 3/4"Z	75HJNCZ	0
7	PIN, 1 X 2"	B-5030	2	20	BOLT, 3/4"SQ HD SET	75SHS2.5CP5	0
8	HAIR PIN, 3/32"	B-5110	4	21	NUT, 3/4"Z	75HNCZ	8
9	BOLT, 7/8 X 6 1/2"	87HCS6.5CP8	1	22	LOCK WASHER, 3/4"Z	75LWZ	8
10	LOCK WASHER, 7/8"Z	87LWZ	1	23	GREASE ZERK, 1/4-28	B-4805	1
11	NUT, 7/8"Z	87HNCZ	1	24	BOLT, 3/4 X 3 1/2"	75HCS3.5CZ5	4
				24A	BOLT, 3/4 X 4 1/2"	75HCS4.5CZ5	0

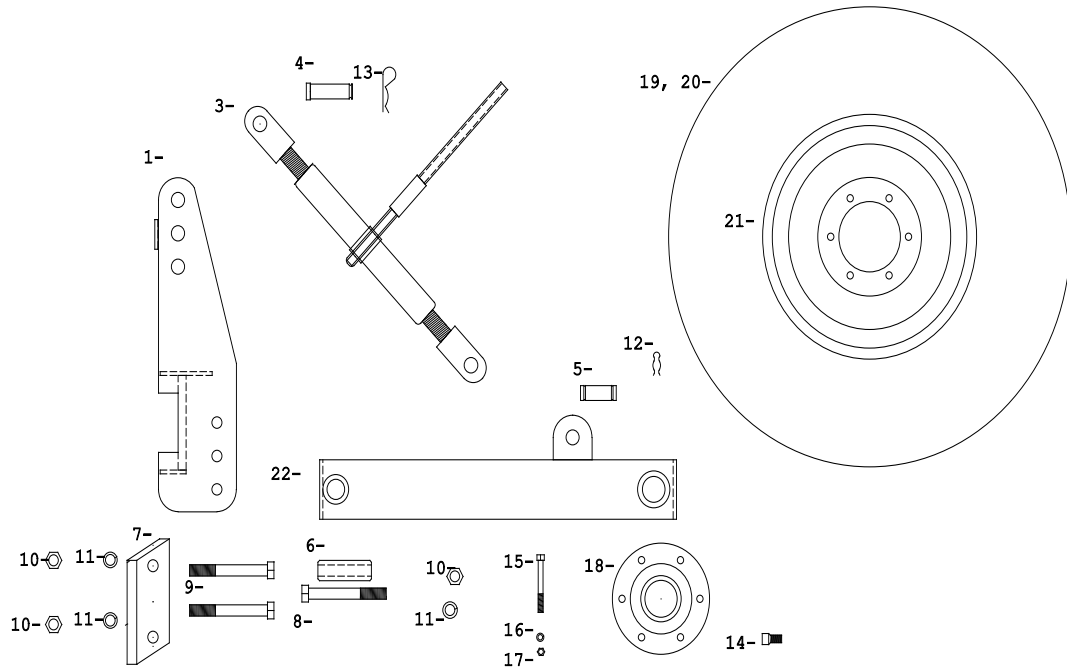

GAUGE WHEEL ASSEMBLY: A-2200

#	DESCRIPTION	PART NO	RE	#	DESCRIPTION	PART NO	RE
1	MAST	B-3000	2	12	HAIR PIN, 3/32"	B-5110	4
2	GAUGE WHEEL STRUT	B-2200	2	13	HAIR PIN, 3/16"	B-5070	2
3	RATCHET JACK	B-3030	2	14	LUG BOLT, 1/2 X 1"	50LB1.0FZ	12
4	PIN, 1 X 2 7/8"	B-5050	2	15	BOLT, 1/2 X 3 1/2"	50HCS3.5CZ5	2
5	PIN, 1 X 2"	B-5030	2	16	LOCK WASHER, 1/2"	50LWZ	2
6	BUSHING, 1.365 X 4.125	B-9702	2	17	NUT, 1/2" Z	50HNCZ	2
7	NUT PLATE	B-3050	4	18	HUB/SPINDLE ASSY	B-2210	2
8	BOLT, 3/4 X 6"	75HCS6.0CZ5	2	19	TIRE, 7.60-15	B-2212	2
9	BOLT, 3/4 X 6 1/2"	75HCS6.5CZ5	8	20	TUBE, 7.60-15	B-2213	2
10	NUT, 3/4" Z	75HNCZ	10	21	RIM, 15 X 8	B-2211	2
11	LOCK WASHER, 3/4" Z	75LWZ	10	22	GREASE ZERK, 1/4-28	B-4805	2

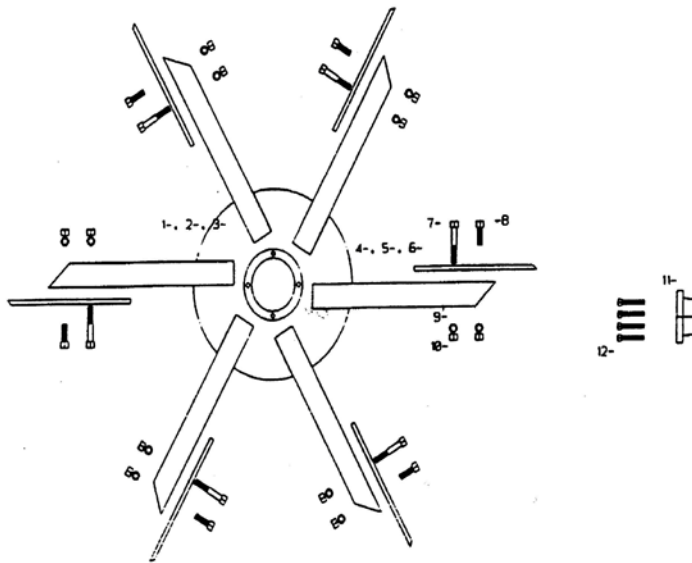

**SPIDER ASSEMBLIES:
A-2000 (PICTURED),
A-2001, A-2002, A-2004**

#	DESCRIPTION	PART NO	QTY A-2000	QTY A-2001	QTY A-2002	QTY A-2003
1	SIX SPOKE SPIDER	B-2000	1			
2	SEVEN SPOKE SPIDER	B-2001		1		
3	FIVE SPOKE SPIDER	B-2002			1	
	NINE SPOKE SPIDER	B-2003				1
4	5 X 7" BLADE	B-2011	6	7	5	9
5	4 X 6" BLADE	B-2012	6	7	5	9
6	3 X 5" BLADE	B-2014	6	7	5	9
7	BOLT, 1/2 X 3" G5Z	50HCS3.0CZ5	6	7	5	9
8	BOLT, 1/2 X 1 1/2" G5Z	50HCS1.5CZ5	6	7	5	9
9	LOCK WASHER, 1/2"	50LWZ	12	14	10	18
10	HEX NUT, 1/2"	50HNCZ	12	14	10	18
11	TAPERLOCK BUSHING	B-2003	1	1	1	1
12	BOLT, 3/8 X 2 1/4" G8P	37HCS2.25CP8	4	4	4	4

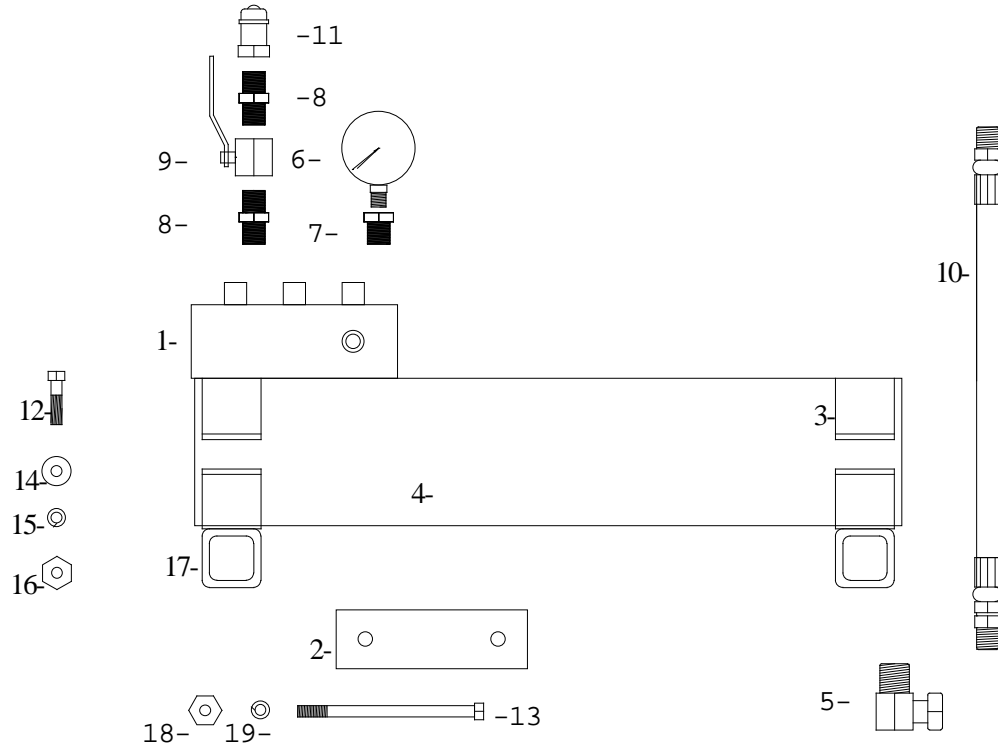

**HYDRAULIC ACCUMULATOR ASSY, 1 GAL:
A-3540**

#	DESCRIPTION	PART NO	RE	#	DESCRIPTION	PART NO	RE
1	ACC. MT. BRACKET	B-3550	1	11	PIONEER MALE END	B-3565	1
2	NUT PLATE	B-3080	2	12	BOLT 3/8 X2 1/2"	37HCS2.5CZ5	4
3	HALF BAND	C-5200	1	13	BOLT, 1/2 X 7"	50HCS7.0CZ5	4
4	ACCUMULATOR, 1 GAL	B-3540	1	14	FLAT WASHER, 3/8"	37FWZ	8
5	ELBOW 90 DEG.	B-3545	1	15	LOCK WASHER, 3/8"	37LWZ	4
6	GAUGE, 3000 PSI, LF	B-3580	1	16	NUT, 3/8"	37HNCZ	4
7	REDUCER BUSHING	B-3590	1	17	ACCUM. SUPP. BRKT	B-3550-2	2
8	CLOSE NIPPLE	B-3570	2	18	NUT, 1/2"	50HNCZ	4
9	BALL VALVE	B-3560	1	19	LOCK WASHER, 1/2"	50LWZ	4
10	HYDRAULIC HOSE	B408108J0848	1				

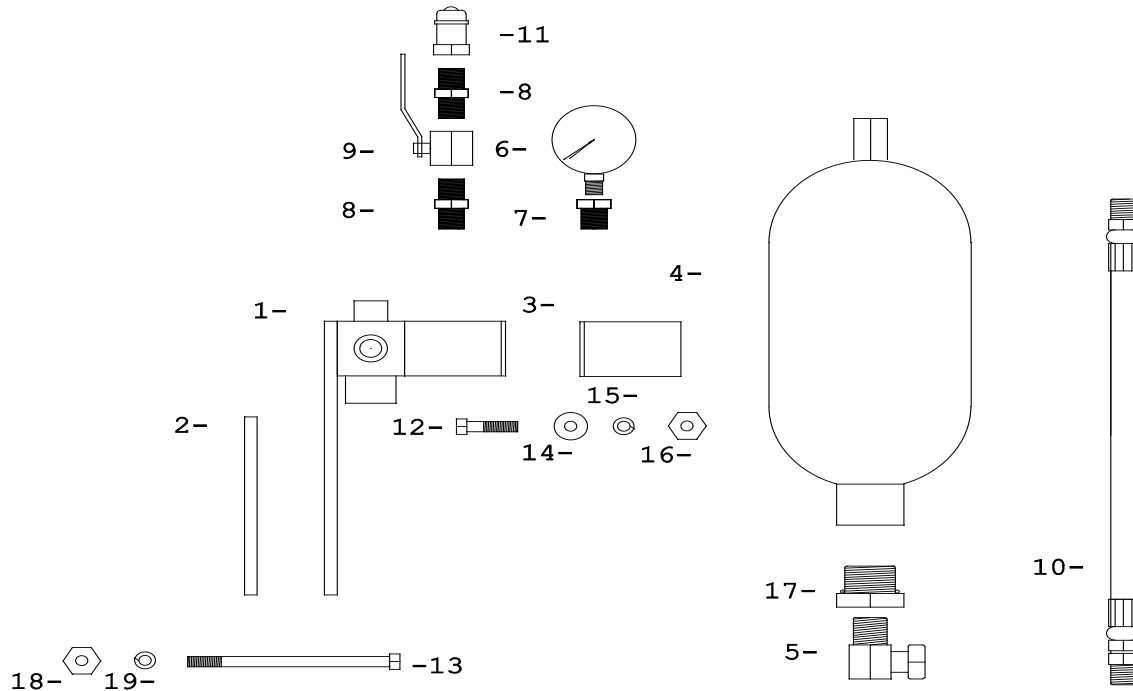

HYDRAULIC ACCUMULATOR ASSY, 2 1/2 GAL.: A-3545

#	DESCRIPTION	PART NO	RE	#	DESCRIPTION	PART NO	RE
1	AC. MT. BRACKET	B-3551	1	11	PIONEER MALE END	B-3565	1
2	NUT PLATE	B-3081	1	12	BOLT, 3/8 X 2 1/2"	37HCS2.5CZ5	2
3	HALF BAND	C-5220	1	13	BOLT, 1/2 X 5.5"	50HCS5.5CZ5	2
4	ACCUMULATOR	B-3541	1	14	FLAT WASHER, 3/8"	37FWZ	4
5	ELBOW, 90 DEG.	B-3546	1	15	LOCK WASHER, 3/8"	37LWZ	2
6	GAUGE, 3000 PSI, LF	B-3580	1	16	NUT 3/8" Z	37HNCZ	2
7	REDUCER BUSHING	B-3590	1	17	ACC. FITTING, RB	B-3547	1
8	CLOSE NIPPLE	B-3570	2	18	LOCK WASHER, 1/2"	50LWZ	2
9	BALL VALVE	B-3560	1	19	NUT, 1/2" Z	50HNCZ	2
10	HYDRAULIC HOSE	B416116J1648	1				

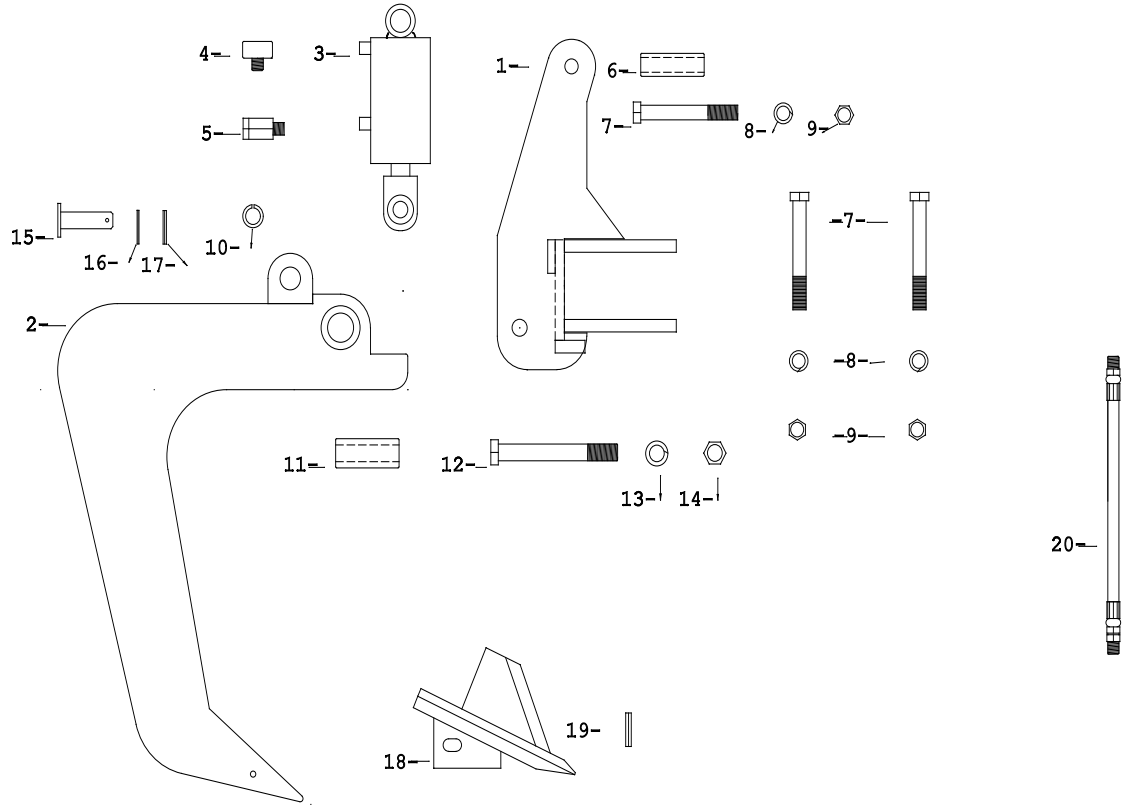

**HYDRAULIC RESET SHANK ASSEMBLY:
A-2508, A-2509**

#	DESCRIPTION	PART NO	RE	#	DESCRIPTION	PART NO	RE
1	MAST HYD. SHANK	B-3010	1	11	BUSHING	B-9705	1
2	HYD. SHANK, 1 1/4"	B-2508	1	12	BOLT, 1 X 6 1/2"	100HCS6.5CP8	1
2A	HYD. SHANK, 1"	B-2509	1	13	LOCK WASHER, 1"	100LWZ	1
3	HYD. CYLINDER	B-3500	1	14	HEX NUT, 1"	100HNCZ	1
4	TEE, 1/2"	B-3520	1	15	PIN, CYLINDER	B-5040	1
5	BREATHER	B-3510	1	16	ROLL PIN, 1/8"	12RP2.0Z	1
6	BUSHING	B-9707	1	17	ROLL PIN, 7/32"	21RP2.0Z	1
7	BOLT, 7/8 X 6 1/2"	87HCS6.5CP8	3	18	SHARKFIN WEAR PT.	B-2703	1
8	LOCK WASHER 7/8"	87LWZ	3	19	ROLL PIN, 3/8"	37RP2.0Z	1
9	HEX NUT, 7/8"	87HNCZ	3	20	HYDRAULIC HOSE	B408108J0838	1
10	HT BUSHING	B-5400	1	21	GREASE ZERK	B-4805	3

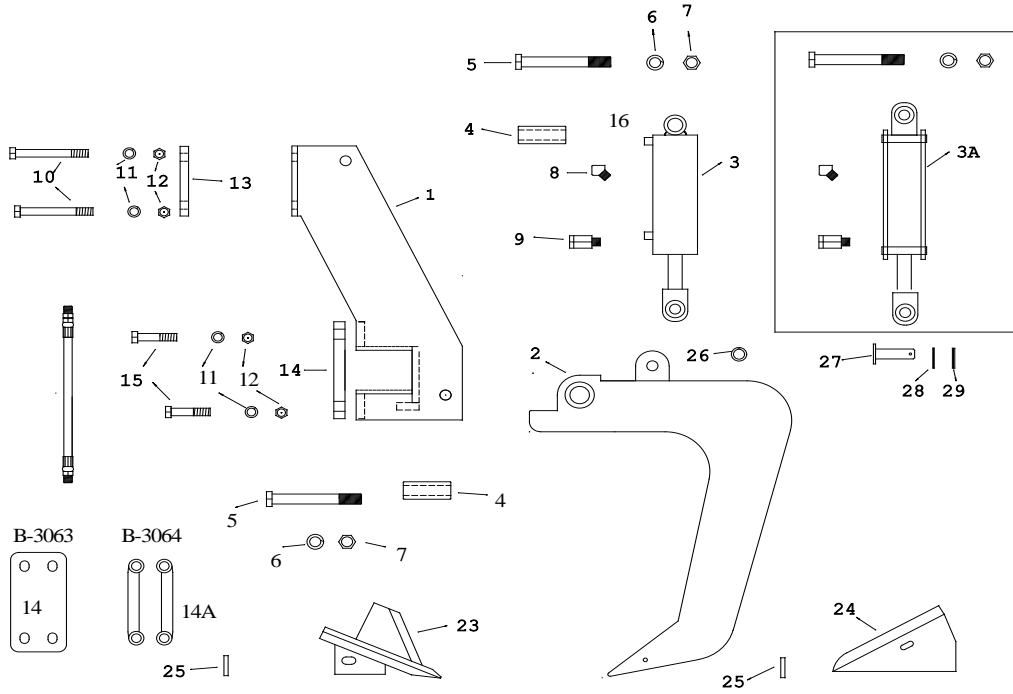

**TM 1 & 1 ¼" HYD. RESET SHANK: A-2508-TM,
A-2509-TM, A-2518-TM, A-2519-TM**

#	DESCRIPTION	PART NO	RE	#	DESCRIPTION	PART NO	RE
1	TM HI LIFT MAST	B-3017	1	12	HEX NUT, ¾" Z	75HNCZ	6
2	HYD RS SHANK, 1 ¼"	B-2508HL	1	13	NUT PLATE, ¾x2 ½ x7"	B-3050	1
2A	HYD RS SHANK, 1"	B-2509HL		14	NUT PLATE, ¾x5x10"	B-3063	1
2B	HYD RS SHANK, 1"EXT	B-2519		14A	NUT PLATE, OPTIONAL	B-3064	
2C	HYD RS SHANK, 11/4EXT	B-2518		15	BOLT, ¾ x 3 ½"	75HCS3.5CZ	4
3	HYD CYLINDER, 3	B-3495	1	15A	BOLT, ¾ x 4 ½"OPTIONAL	75HCS4.5CZ	4
3A	HYD CYLINDER, 3 x 8" W	B-3496		16	BLEEDER VALVE	B-3700	1
4	BUSHING, 1.74 x 4.24"	B-9705	2	23	SHARKFIN WEAR POINT	B-2703	1
5	BOLT, 1 x 6 ½"	100HCS6.5CP	2	24	LG DYKO WEAR POINT,	B-2708	
6	LOCK WASHER 1" Z	100LWZ	2	24A	SF WEAR POINT, 1"	B-2712	
7	HEX NUT, 1" Z	100HNCZ	2	25	ROLL PIN, 3/8x2" Z	37RP2.0Z	1
8	ELBOW, ½"45, MF	B-3522	1	26	HT BUSHING, 1 3/8x1x1"	B-5400	1
9	BREATHER, ½"	B-3510	1	27	PIN, CYLINDER	B-5040	1
10	BOLT, ¾x6 ½"	75HCS6.5CZ5	2	28	ROLL PIN, 1/8 x 2" Z	12RP2.0Z	1
11	LOCK WASHER, ¾" Z	75LWZ	6	29	ROLL PIN, 7/32 x 2" Z	21RP2.0Z	1
	GREASE ZERK, ¼-28	B-4805	3				

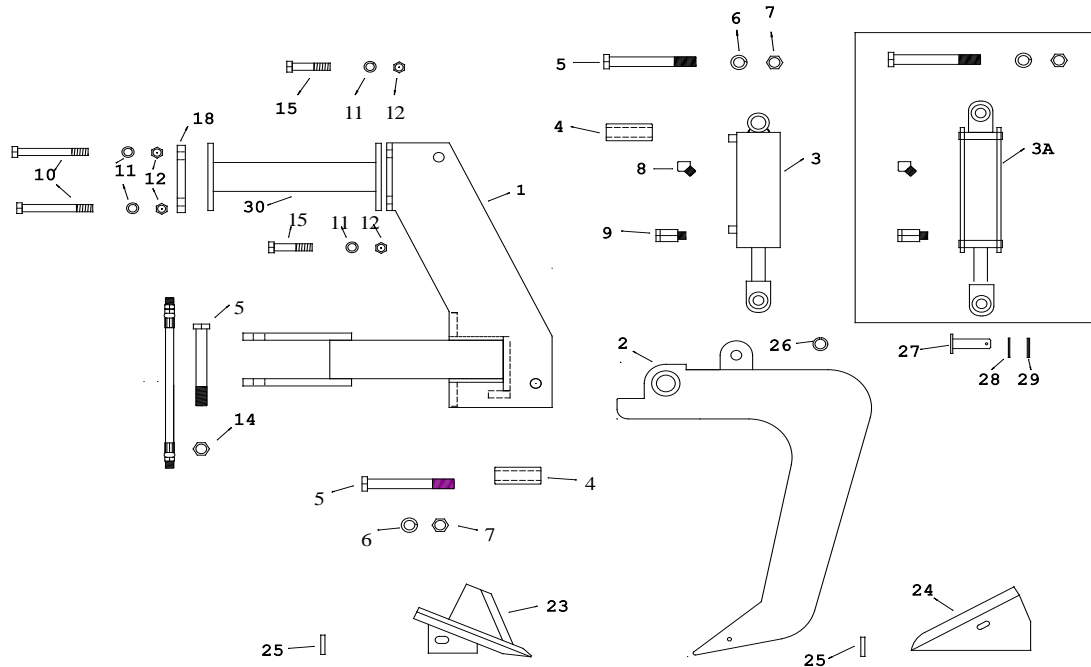

**TM HYDRAULIC SETBACK SHANK ASSY:
A-2508-TMB, A-2509-TMB, A-2518-TMB, A-2519-TMB**

#	DESCRIPTION	PART NO	RE	#	DESCRIPTION	PART NO	RE
1	TM HI LIFT MAST	B-3018	1	12	HEX NUT, 3/4" Z	75HNCZ	4
1A	TM HI LIFT MAST	B-3018-20		15	BOLT, 3/4 x 2 1/2"	75HCS2.5CZ	2
2	HYD RS SHANK, 1	B-2508HL	1	16	BLEEDER VALVE	B-3700	1
2A	HYD RS SHANK,	B-2509HL		18	NUT PLATE, 3/4x2 1/2 x7"	B-3050	1
2B	HYD RS SHANK,	B-2519		23	SHARKFIN WEAR POINT	B-2703	1
2C	HYD RS SHANK,	B-2518		24	LG DYKO WEAR POINT,	B-2708	
3	HYD CYLINDER, 3	B-3495	1	24A	SF WEAR POINT, 1"	B-2712	
3A	HYD CYLINDER, 3	B-3496		25	ROLL PIN, 3/8x2" Z	37RP2.0Z	1
4	BUSHING, 1.74 x	B-9705	2	26	HT BUSHING, 1 3/8x1x1"	B-5400	1
5	BOLT, 1 x 6 1/2"	100HCS6.5CP8	4	27	PIN, CYLINDER	B-5040	1
6	LOCK WASHER 1"	100LWZ	4	28	ROLL PIN, 1/8 x 2" Z	12RP2.0Z	1
7	HEX NUT, 1" Z	100HNCZ	4	29	ROLL PIN, 7/32 x 2" Z	21RP2.0Z	1
8	ELBOW, 1/2"45, MF	B-3522	1	30	MAST BRIDGE SPACER	B-1870	1
9	BREATHER, 1/2"	B-3510	1	30A	MAST BRIDGE SPACER	B-1870-20	
10	BOLT, 3/4x6 1/2"	75HCS6.5CZ5	2		GREASE ZERK, 1/4-28	B-4805	3
11	LOCK WASHER,	75LWZ	4				

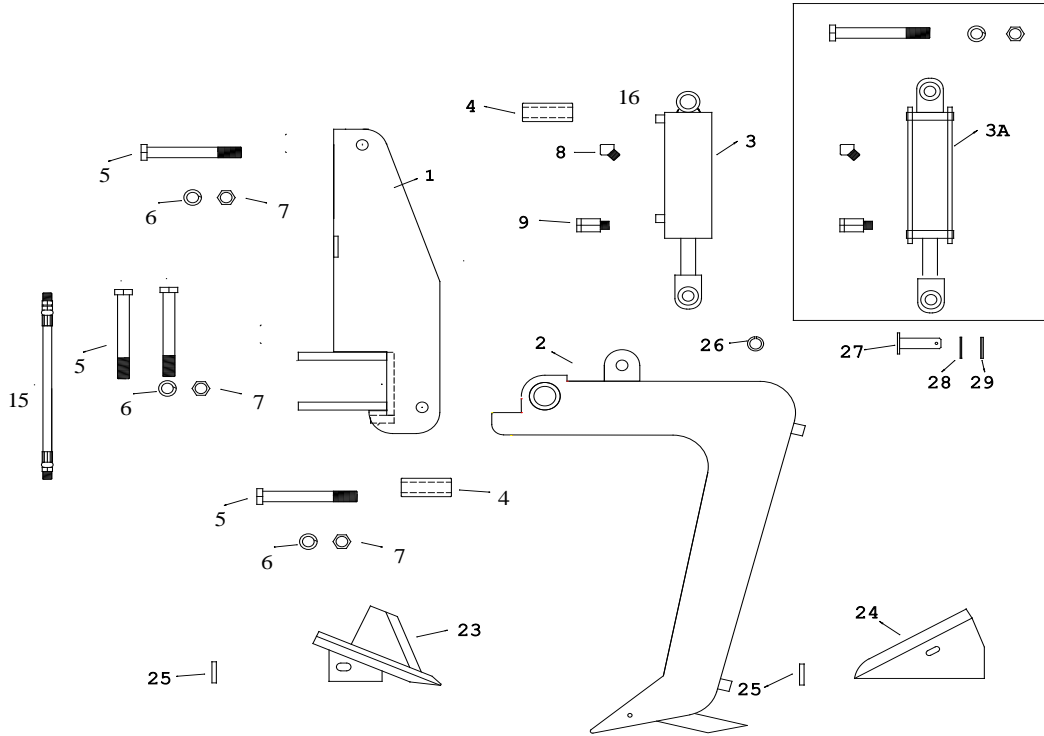

**HI-LIFT HYDRAULIC RESET SHANK ASSEMBLY:
A-2518HL, A-2508HL**

#	DESCRIPTION	PART NO	RE	#	DESCRIPTION	PART NO	RE
1	MAST, HYD. HI-LIFT	B-3015	1	8	TEE, 1/2"	B-3520	1
2	HYD RS SHANK, 1 1/4" EXT	B-2518	1	9	BREATHER, 1/2"	B-3510	1
2A	HYD RS SHANK, 1 1/4"	B-2508HL		15	HYDRAULIC HOSE	B408108J0838	1
3A	HYD CYLINDER, 3x8" W	B-3496		23	SHARKFIN WEAR PT	B-2703	1
3	HYD CYLINDER, 3 1/2x8"	B-3495	1	24	LG DYKO WEAR PT	B-2708	
4	BUSHING, 1.74x4.24"	B-9705	2	24A	SF WEAR POINT 1"	B-2712	
5	BOLT, 1 x 6 1/2"	100HCS6.5CP8	4	25	ROLL PIN, 3/8" Z	37RP2.0Z	1
6	LOCK WASHER, 1"	100LWZ	4	27	PIN, CYLINDER	B-5040	1
7	HEX NUT, 1"	100HNCZ	4	28	ROLL PIN, 1/8" Z	12RP2.0Z	1
				29	ROLL PIN, 7/32" Z	21RP2.0Z	1

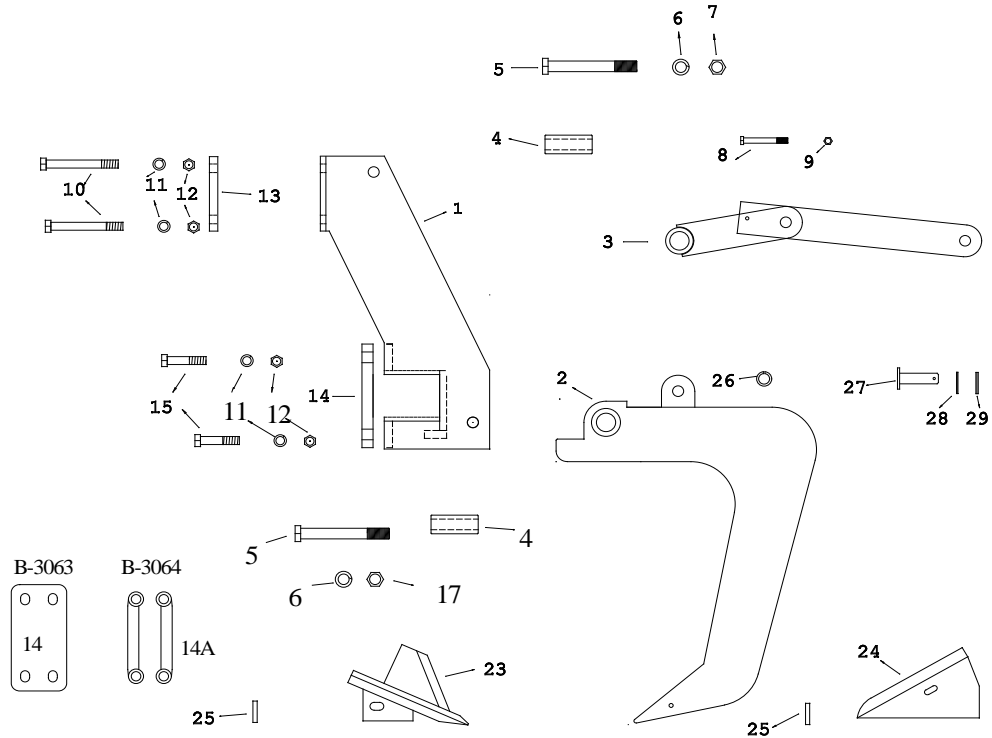

**AE 1" & 1 ¼" SHEAR TRIP SHANK ASSEMBLIES:
A-2508-TMT, A-2509-TMT**

#	DESCRIPTION	PART NO	RE	#	DESCRIPTION	PART NO	RE
1	TM HI LIFT MAST	B-3017	1	13	NUT PLATE, ¾ x 2 ½ x 7"	B-3050	1
2	HYD RS SHANK, 1 ¼"	B-2508HL	1	14	NUT PLATE, ¾ x 5 x 10"	B-3063	1
2A	HYD RS SHANK, 1"	B-2509HL		14A	NUT PLATE, OPTIONAL	B-3064	2
3	SB LINKAGE	B-2530	1	15	BOLT, ¾ x 3 ½"	75HCS3.5CZ5	4
4	BUSHING, 1.74x4.25"	B-9705	2	15A	BOLT, ¾ x 4 ½"	75HCS4.5CZ5	4
5	BOLT, 1 x 6 ½"	100HCS6.5CP8	2	23	SHARKFIN WEAR	B-2703	1
6	LOCK WASHER 1"	100LWZ	2	24	LG DYKO WEAR POINT	B-2708	
7	HEX NUT, 1" Z	100HNCZ	2	24A	SF WEAR POINT, 1"	B-2712	
8	SHEAR BOLT, 3/8"	37HCS2.5CZ5	1	25	ROLL PIN, 3/8 x 2", Z	37RP2.0Z	1
9	HEX NUT, FL 3/8"	37LNSFCZ	1	26	HT BUSHING, 1 3/8 x 1"	B-5400	1
10	BOLT, ¾ x 6 ½"	75HCS6.5CZ5	2	27	PIN FOR MARKER, 1 x	B-5045	2
11	LOCK WASHER, ¾"	75LWZ	6	29	ROLL PIN, 7/32 x 2"	21RP2.0Z	2
12	HEX NUT, ¾"	75HNCZ	6				

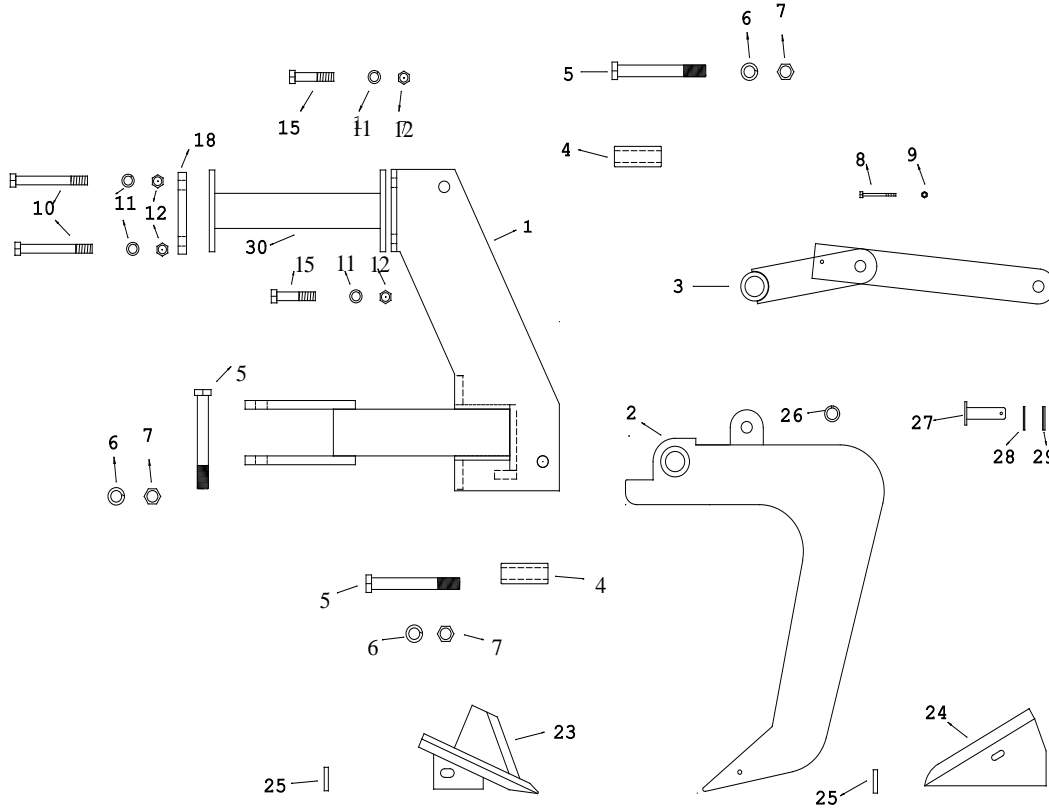

**AE 1" & 1 ¼" SETBACK SHEAR TRIP SHANK ASSEMBLIES:
A-2508-TMTB, A-2509-TMTB**

#	DESCRIPTION	PART NO	RE	#	DESCRIPTION	PART NO	RE
1	TM HI LIFT MAST W/SB	B-3018	1	11	LOCK WASHER, ¾"	75LWZ	
1A	TM HI LIFT MAST W/SB	B-3018-20		12	HEX NUT ¾"	75HNCZ	4
2	HYD RS SHANK 1 ¼"	B-2508HL	1	15	BOLT, ¾ x 2 ½"	75HCS2.5CZ5	2
2A	HYD RS SHANK 1"	B-2509HL		18	NUT PLATE, ¾ x 2 ½ x 7"	B-3050	1
3	SHEAR BOLT LINKAGE	B-2530	1	23	SHARKFIN WEAR POINT	B-2703	1
4	BUSHING, 1.74x4.25"	B-9705	2	24	LG DYKO WEAR POINT 1"	B-2708	
5	BOLT, 1 x 6 ½"	100HCS6.5CP8	4	24A	SF WEAR POINT, 1"	B-2712	
6	LOCK WASHER, 1"	100LWZ	4	26	HT BUSHING, 1 3/8 x 1"	B-5400	1
7	HEX NUT, 1"	100HNCZ	4	27	PIN FOR MARKERS, 1x2"	B-5045	2
8	SHEAR BOLT, 3/8"	37HCS2.5CZ5	1	25	ROLL PIN, 3/8 x 2"	37RP2.OZ	1
9	HEX NUT, 3/8"	37LNSFCZ	1	29	ROLL PIN, 7/32 x 2"	21RP2.OZ	2
10	BOLT, 3/4 x 6 ½"	75HCS6.5CZ5	2				

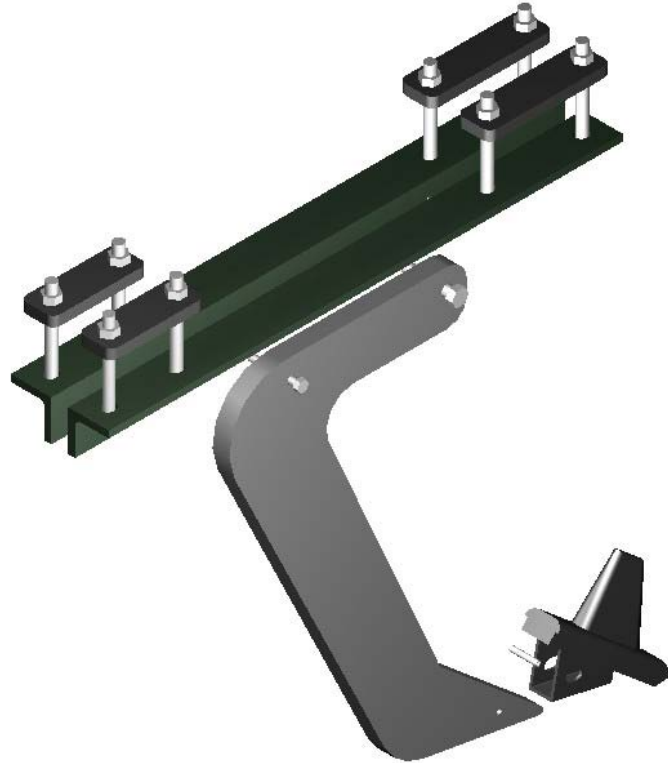

ANGULAR SHANK AND CLAMP ASSEMBLY

A-2505 AND A-2603-24

PART	DESCRIPTION	PART NO.	REQ
1	ANGLE CLAMP LEFT	B-2603-38-L	1
2	ANGLE CLAMP RIGHT	B-2603-38-R	1
3	NUT PLATE 7 IN.	B-3050	2
4	NUT PLATE 9 IN.	B-3060	2
5	ANGULAR SHANK 1 ¼ IN.	B-2505	1
6	SHARKFIN WEARPOINT 1 ¼ IN.	A-2703	1
7	HEX CAP SCREW ¾ X 6 ½ GRADE 5 Z	75HCS6.5CZ5	8
8	HEX CAP SCREW ¾ X 3 ½ GRADE 5 Z	75HCS3.5CZ5	1
9	HEX NUT ¾ IN. Z	75HNCZ	9
10	LOCK WASHER Z	75LWZ	9
11	HEX CAP SCREW ½ X 3 ½ GRADE 2 Z	50HCS3.5CZ2	1
12	HEX NUT ½ IN. Z	50HNCZ	1
13	LOCK WASHER ½ IN. Z	50LWZ	1

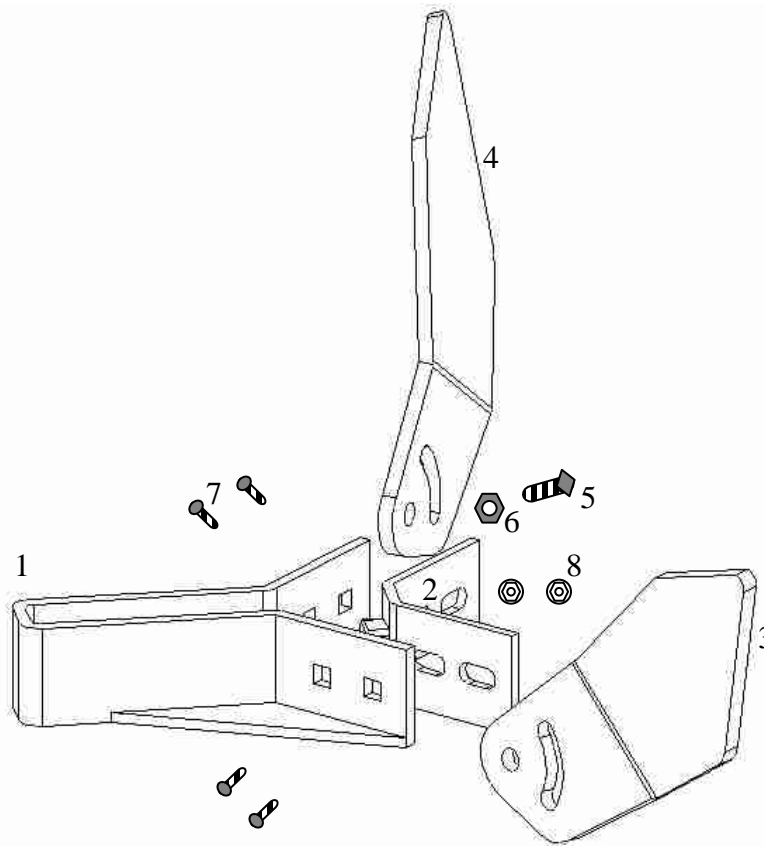

**HILLING WING ASSEMBLY:
A-2800, A-2810, A-2820**

PART	DESCRIPTION	PART No.	RE
1	HW FRONT CLAMP – 1½ COIL	B-2800	1
	HW FRONT CLAMP – 1¼ HYD / ANG	B-2810	1
	HW FRONT CLAMP – 1" HYD / ANG	B-2815	1
2	HW BACK BRACKET	B-2840	1
3	HD ADJ HILLING WING – LEFT	B-2831	1
4	HD ADJ HILLING WING – RIGHT	B-2830	1
5	5/8 X 3 SET SCREW	62SHS3.0CP5	1
6	5/8 HEX NUT	62HNCZ	4
7	CARRIAGE BOLT – ½ x 1½	50CB1.5CZ5	4
8	½ WIZ NUT	50LNSFCZ	4

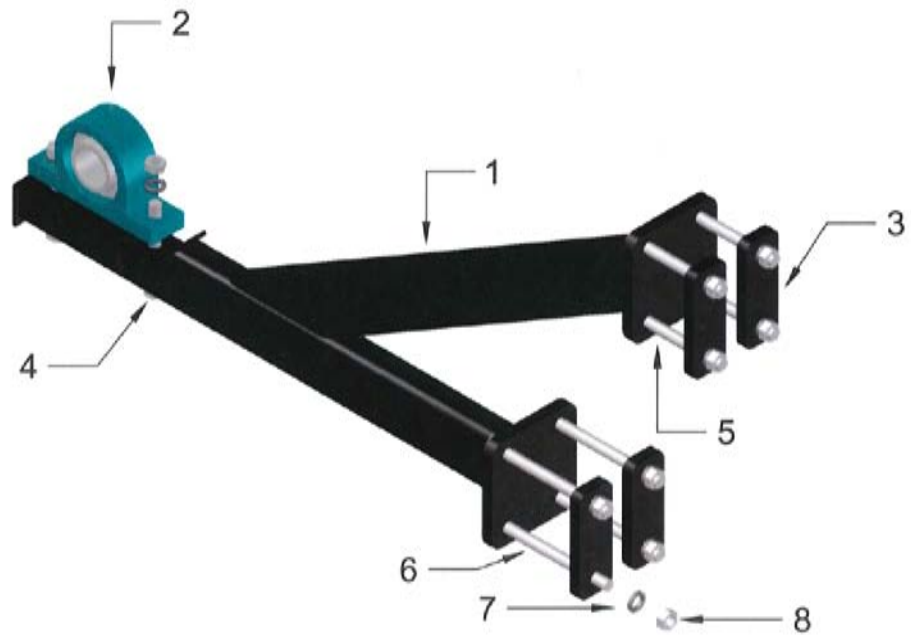

A-2109S

Pocket Pitter Arm Assembly

PART	DESCRIPTION	PART NO.	REQUIRED
1	POCKET PITTEr ARM, SOLID	B-2109S	1
2	PILLOW BLOCK BEARING 2 7/16	B-2105	1
3	NUT PLATE, 7 IN.	B-3050	4
4	HEX CAP SCREW, 3/4 X 5 1/2, G5	75HCS5.5CZ5	4
5	HEX CAP SCREW, 3/4 X 6 1/2, G5	75HCS6.5CZ5	4
6	HEX CAP SCREW, 3/4 X 8 1/2, G5	75HCS8.5CZ5	4
7	LOCK WASHER, 3/4 IN.	75LWZ	10
8	HEX NUT, 3/4 IN.	75HNCZ	10

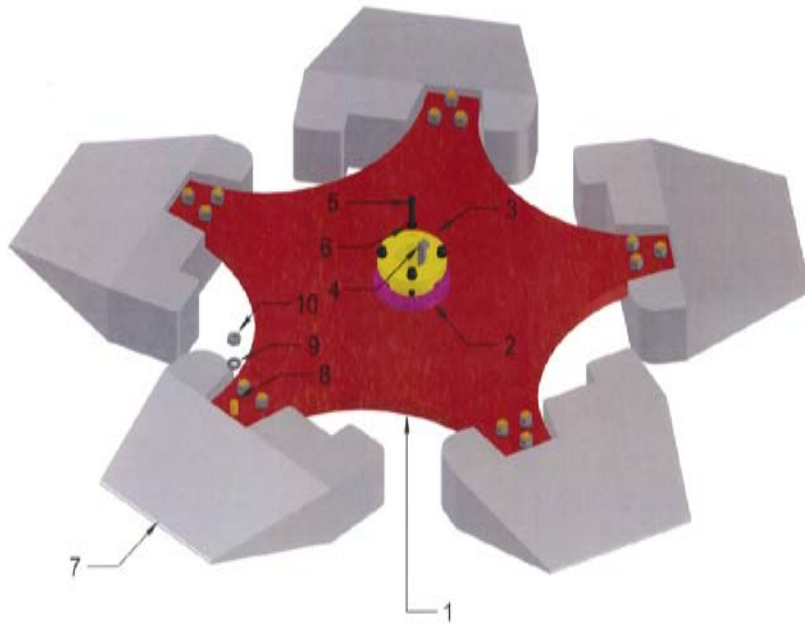

A-2010; A-2010A

POCKET PITTER SPIDER ASSEMBLY

PART	DESCRIPTION	PART NO.	REQUIRED
1	POCKET PITTER SPIDER	B-2010-5	1
2	WELD-IN HUB	C-2025	1
3	TAPER LOCL BUSHING	B-2005	1
4	KEY STOCK, 5/8 IN.	B-3201	1
5	HEX CAP SCREW, 7/16 X 1 ½, G8	41HCS1.5CP8	4
6	LOCK WASHER, 7/16 IN., PLAIN	41LWP	4
7	POCKET PITTER CASTING, 4 IN.	B-2010	5
7A	POCKET PITTER CASTING, 2 ½ IN.	B-2010A	5
8	HEX CAP SCREW, 5/8 X 3 ½, G8	621HCS3.5CZ8	15
9	LOCK WASHER, 5/8, PLATED	62LWZ	15
10	HEX NUT, 5/8 IN.	62HNCZ	15

